

Hi-Abuse[®] BRAND XP[®] **Hi-Impact[®] BRAND XP[®]**

Gypsum Wallboard Systems Guide



National 
Gypsum[®]

Table of Contents

SECTION	PAGE
Introduction	2
Understanding Test Methods of High Performance Wall Systems	3
Defining Abuse and Impact Resistance	3
Why Choose National Gypsum?	3
High Performance Wallboard Panel Test Methods	4
Categories of Performance for Hi-Abuse® BRAND XP® and Hi-Impact® BRAND XP® Panels	5
ABUSE RESISTANT SYSTEMS	
Hi-Abuse® BRAND XP® Wallboard	6
Hi-Abuse® BRAND XP® Technical Information	8
Hi-Abuse® BRAND XP® Fire-Rated Selector Guide	9
IMPACT RESISTANT SYSTEMS	
Hi-Impact® BRAND XP® Wallboard	10
Hi-Impact® BRAND XP® Technical Information	12
Hi-Impact® BRAND XP® over Hi-Impact® BRAND XP®	13
Hi-Impact® BRAND XP® Fire-Rated Selector Guide	14
Mold Resistance Products and Recommendations by National Gypsum	15
Handling and Construction Practices	15
Additional Sources of Information	15



Introduction

“High traffic” is a relative term when it comes to a building project. Any residential, institutional or commercial building can include such a space, but the amount of wear and tear in store for a residential garage, for example, is quite different from that expected for a psychiatric ward. Regardless of the application, however, there are two types of potential damage that architects must consider when specifying a wall system for a high-traffic area:

Abuse Resistance – Abrasion or scuffing due to high traffic during standard use, and indentation of the wall surface from occasional contact.

Impact Resistance – Damage due to high energy or continual impact that breaks into the stud cavity.

Using appropriate materials to resist damage not only contributes to long-term aesthetics but also decreases maintenance costs of repairing scuffs and dents on the wall surface or intrusion into the wall cavity. Until recently, however, material selection has been limited for high-traffic spaces. To increase wall strength, many architects have specified concrete masonry units (CMU), which provide damage resistance for both



surface damage and penetration, but the masonry units can significantly limit design choices while increasing material and labor costs.

In response to this, the gypsum wallboard industry has developed specialized high-performance wall panels to provide architects with appropriate and cost-effective resistance to damage, while keeping design flexibility high. These materials, along with proper assemblies, have helped bridge the gap between strength and design.

Why Choose National Gypsum?

No other manufacturer offers a more comprehensive line of paper faced, abuse, impact, mold, mildew and moisture resistant drywall systems in the industry.

Hi-Abuse XP and Hi-Impact XP install, finish and accept decoration easier than paperless drywall panels.



The XP Advantage

XP = Xtra Protection against mold, mildew and moisture when used in conjunction with good design, handling and construction practices. The **XP** mold resistant technology is an *Active* process that chemically bonds an antimicrobial ingredient into the fibers of the face and back paper as the paper is produced at our paper plants.

The *Active* process neutralizes the organic food source in the paper creating a **modified** paper-faced mold resistant gypsum panel. The antimicrobial ingredient is not spray applied and cannot be rubbed or abraded off, and creates a panel that allows the same installation, finishing and decoration as standard wallboard.

Understanding Test Methods and High Performance Wall Systems

Currently, the industry does not have standardized test methods for evaluating high performance panels. Manufacturers of these panels are using existing ASTM test methods, originally developed to test different types of material, and modifying them to measure the performance of gypsum based panels. An ASTM task group has been formed and is drafting new test standards that will be specifically designed to test high performance gypsum based panels. Until such test methods have been formally adopted, some ASTM test methods will be listed as "modified."

The test methods described and used in this selection guide are the current industry proposed test methods that ASTM is considering for formal adoption.

High performance panels can be manufactured with completely different kinds of raw material and technology. Gypsum based panels can be reinforced with heavy layers of paper and mesh, or other technologies that include fiberglass facings or wood cellulose fibers. When comparing one brand of high performance panels to another, consider performance as well as the desired final appearance. Manage the expectations of the final appearance with a product that most resembles what is expected.

The purpose of this brochure is to simplify the evaluation and selection process. Use this information to keep up with the industry as it develops, and to select panels that will meet and exceed your expectations.

Defining Abuse and Impact Resistance

Abuse resistant drywall has become a generic phrase to describe gypsum based panels offering greater strength than standard drywall. While offering a stronger core than standard drywall, abuse resistant panel's primary function is to provide surface protection against scuffs, scratches and dents.

Impact resistant panels offer a similar abuse resistant surface while providing increased resistance to panel failure from impacts. Making this distinction can simplify the selection process and potentially save you money by not over-engineering your walls.

High Performance Wallboard Panel Test Methods

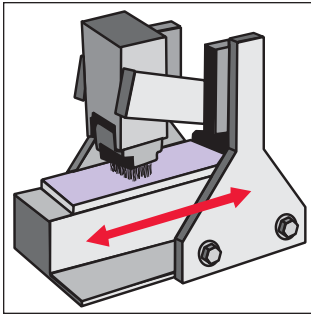

Surface Abrasion (Modified ASTM D 4977)

This test measures the ability of a gypsum panel surface to resist scratches and scuffs by subjecting the panel to 50 back and forth cycles with a wire brush. The depth of the abrasion is measured. The test was originally developed to test granule adhesion to mineral surfaced roofing, and was modified by adding 25 pounds of additional weight to the wire brush.

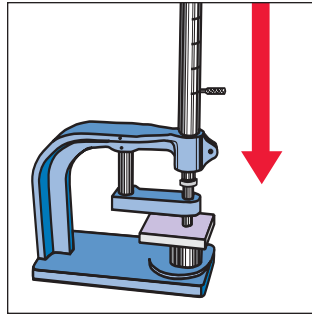

Surface Indentation (ASTM D 5420 – Gardner Impact Test)

This test measures the ability of a gypsum panel to resist dents by a small hard object, by raising and dropping a hemispherical rod onto the gypsum panel. The depth of the indentation is measured. The original test was developed to test flat, rigid sheets of plastic.

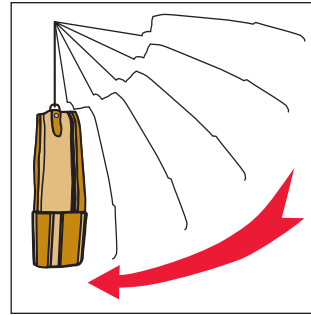

Single Drop Soft Body Impact (Modified ASTM E 695)

This test measures the ability of a gypsum panel to withstand a single impact of a heavy soft object. This test is conducted by swinging a leather bag loaded with steel pellets into the panel. When the panel breaks, the height of the drop and weight of the bag are used to calculate the foot-pound measurement required to break the panel. The test was originally developed to measure relative resistance of wall, floor, and roof construction to impact loading.

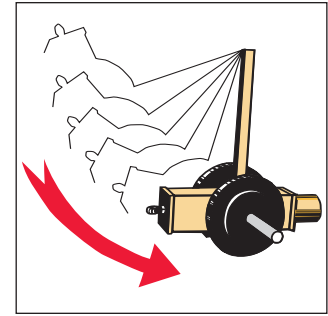

Hard Body Impact (Industry Proposed Standard)

This test measures the ability of a gypsum panel to withstand the impact of a hard object such as a hammer or heel of a boot. A panel is impacted with 2-3/4" steel cylinder mounted to a ram. Weights are added to the ram and the panel is impacted one time. The maximum amount of impact force the panel can withstand without breaching the stud cavity is reported. This is a new test proposed by manufacturers of high performance panels.

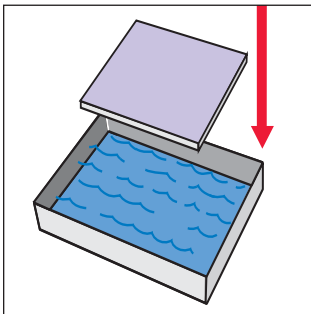

Water Absorption Test (ASTM C 473)

This test is not part of the proposed ASTM standard for testing abuse and impact resistant panels. However, it is a decisive measurement that can be used to compare and distinguish the water resistance of high performance panels. Three dry board samples are cut, conditioned and weighed. Each sample is submerged in a water bath for two hours. The samples are removed, wiped and weighed again. The weight gained is calculated and reported as a percentage. The higher the percentage, the more water the panel absorbed.

Progressive Drop Soft Body Impact (Modified ASTM E 695)

This test measures the ability of a gypsum panel to withstand repeated impacts in the same spot by a heavy soft object. This test is conducted by repeatedly swinging a leather bag loaded with steel pellets into the panel. The panel is impacted at progressively higher drops until the panel breaks. The height of the drop and weight of the bag are used to calculate the foot-pound measurement required to break the panel. The test was originally developed to measure relative resistance of wall, floor, and roof construction to impact loading.

Categories of Performance for Hi-Abuse XP and Hi-Impact XP Panels

National Gypsum Company has developed categories of performance that allows you to match high performance panels with the desired application. The tests utilized in this chart are current industry proposed ASTM test methods. The value ranges used to categorize high performance panels have been assigned by National Gypsum. These value ranges allow products to be classified, simplifying the specification process when alternatives must be listed.

	Gypsum Panel	Surface Abrasion ASTM D 4977	Surface Indentation ASTM D 5420	Prog. Drop Soft Body Impact ASTM E 695	Single Drop Soft Body Impact ASTM E 695	Hard Body Impact Ind. Prop. Standard	
Classification Level		Abraded Depth Maximum (Inches)	Indentation Maximum (Inches)	ft.-lbs. to failure	ft.-lbs. to failure	ft.-lbs. to failure	
Level 1 - Standard Duty							
<ul style="list-style-type: none"> Standard Residential Commercial Applications 	5/8" Type X Wallboard	Greater than 0.250	Greater than 0.200	Less than 200	Less than 200	Not Applicable	
Level 2 - Moderate Duty							
Residential <ul style="list-style-type: none"> Stairways Garages 	<ul style="list-style-type: none"> Public Housing 						
Commercial <ul style="list-style-type: none"> Public Areas 	<ul style="list-style-type: none"> Corridors 	Hi-Abuse XP Wallboard	Less than 0.250	Less than 0.200	Between 100 & 200	Between 200 & 500	Not Applicable
Institutional <ul style="list-style-type: none"> Schools Dormitories 	<ul style="list-style-type: none"> Day Care Centers Health Care Facilities 						
Level 3 - Heavy Duty							
Commercial <ul style="list-style-type: none"> Shopping Centers Airports 	<ul style="list-style-type: none"> Mail Rooms Loading Docks 						
Institutional <ul style="list-style-type: none"> Court Houses Police Stations Schools Dormitories 	<ul style="list-style-type: none"> Gymnasiums Sports Facilities Health Care Facilities Correctional Facilities 	Hi-Impact XP Wallboard with fiberglass mesh	Less than 0.250	Less than 0.200	Greater than 400	Greater than 500	Between 150 & 250
Level 4 - Maximum Duty							
Commercial <ul style="list-style-type: none"> Shopping Centers Airports 	<ul style="list-style-type: none"> Mail Rooms Loading Docks 						
Institutional <ul style="list-style-type: none"> Court Houses Police Stations Schools Dormitories 	<ul style="list-style-type: none"> Gymnasiums Sports Facilities Health Care Facilities Correctional Facilities 	Double layer of Hi-Impact XP Wallboard with fiberglass mesh	Less than 0.250	Less than 0.200	Greater than 400	Greater than 500	Greater than 250

Hi-Abuse[®] BRAND XP[®] Wallboard

Classification Level 2 – Moderate Duty

- | | | |
|----------------------|---------------------------------|--|
| Residential | • Public Housing
• Stairways | • Garages |
| Commercial | • Public Areas | • Corridors |
| Institutional | • Schools
• Dormitories | • Day Care Centers
• Health Care Facilities |

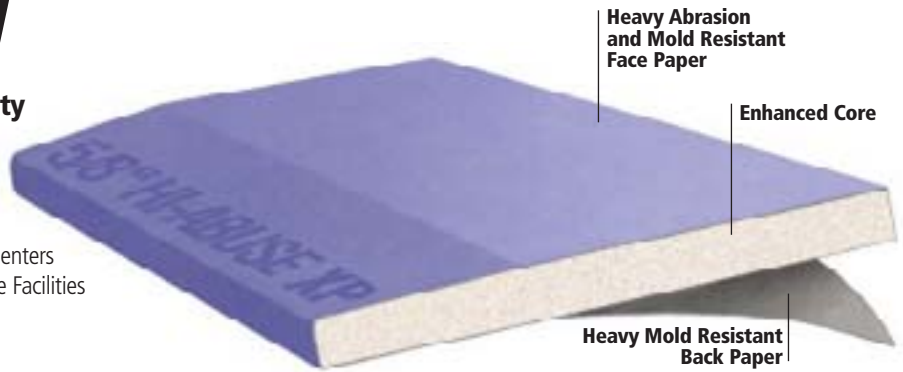

Description

Hi-Abuse[®] BRAND XP[®] Wallboard panels consist of a tapered edge, fire resistant Type X gypsum core encased in heavy, smooth, abrasion resistant, mold/mildew resistant, 100% recycled purple paper on the face side and 100% recycled heavy mold/mildew resistant liner paper on the back side.

Hi-Abuse XP Wallboard is designed to provide extra protection against mold and mildew compared to standard wallboard products. The panels feature a specially formulated core to provide greater resistance to surface indentation and abuse.

Applications

This unique wallboard is designed for use in wall assemblies in areas where surface durability, indentation, and mold/mildew resistance are major concerns. 5/8" Fire-Shield Hi-Abuse XP panels may be used where Type X gypsum panels are specified in fire-rated wall and floor-ceiling assemblies (e.g., UL U300, U400, V400 and L500 series).

Limitations

- Exposure to excessive or continuous moisture and extreme temperatures should be avoided.
- Not recommended where it will be exposed to temperatures exceeding 125°F (52°C) for extended periods of time.
- Must be stored off the ground and under cover. Sufficient risers must be used to ensure support for the entire length of the wallboard to prevent sagging.

Applicable Standards

- ASTM C 36/C 1396

Accessories

- Fasteners: drywall screws
- ProForm[®] BRAND Joint Tape
- ProForm[®] BRAND XP[®] Ready Mix or ProForm[®] BRAND Sta-Smooth[®]/Sta-Smooth[®] Lite Setting Compound
- Cornerbead, Trims, Casing beads
- Furring channels
- E-Z Strip control joints or .093 zinc control joints

FEATURES	BENEFITS
Encased in heavy, smooth, purple, abrasion, mold and mildew resistant, 100% recycled paper	<ul style="list-style-type: none"> ■ Resists the growth of mold per ASTM D 3273 with a score of 10, the best possible score for this test ■ Scuff and scratch resistant ■ Does not require the added strength of a setting type compound for joint reinforcement ■ Allows for same joint treatment reinforcement procedures as standard drywall, thereby reducing costs and the risk of improper installation ■ Accepts a wide range of decorative finishes ■ Provides standard drywall finish appearance
High density, fire resistant, Type X core	<ul style="list-style-type: none"> ■ May be substituted in fire rated wall and floor-ceiling assemblies requiring a Type X core ■ Indentation resistant ■ Transitions into drywall without the use of control joints
Easily scored and snapped	<ul style="list-style-type: none"> ■ Saves time by eliminating the need for special cutting tools and rasping of cut edges ■ Openings and outlet boxes are cut out in same manner as standard wallboard
Lightweight alternative to CMU	<ul style="list-style-type: none"> ■ Faster installation ■ Reduces cost of installation

Installation

- Installation of Hi-Abuse XP Wallboard should be consistent with methods described in Applicable Standards. For best impact performance, use vertical application.
- Hi-Abuse XP wallboard comes standard with GridMarX[®] guide marks, printed on the paper surface. These guide marks align with standard building dimensions and help to quickly identify fastener lines for stud and joist framing. Using GridMarX, accurate cuts can be made without having to draw lines. The use of GridMarX also provides quick identification and uniform nail/screw patterns.
- GridMarX guide marks run the machine direction of the board at five points in 4" increments. Marks run along the edge in both tapers and at 16", 24" and 32" in the field of the board. The marks cover easily with no bleed-through using standard paint products.

Applicable Standards and References

- ASTM C 840
- Gypsum Association GA-216
- Gypsum Association GA-214
- National Gypsum Company, *Gypsum Construction Guide*

Finishing/Decoration

- Tapered edges allow joints to be reinforced with ProForm[®] BRAND Joint Tape and concealed with ProForm[®] BRAND Ready Mix or setting compounds.
- For optimum mold and mildew resistance, National Gypsum recommends ProForm[®] BRAND XP[®] Ready Mix or ProForm[®] BRAND Sta-Smooth/Sta-Smooth Lite Setting Compounds.
- For best painting results, all surfaces, including joint compound, should be clean, dust-free and not glossy. To improve fastener and joint concealment, a coat of quality drywall primer is recommended to equalize the porosities between surface paper and joint compound.
- The selection of a paint to give the specified or desired finish characteristics is the responsibility of the architect or contractor.
- Hi-Abuse XP Wallboard that is to have a wall covering applied to it should be prepared and primed as described for painting.
- Gypsum Associations GA 214, *Recommended Specification of Gypsum Board Finish*, should be referred to in order to determine the level of finishing needed to ensure a surface is properly prepared to accept the desired decoration.

Technical Data

Sizes & Types

- Thickness: 5/8" Type X (15.9mm)
- Width: 4' (1219 mm)
- Lengths: 8' through 12' (2438 mm-3658 mm)
- Edges: Tapered

Surface Burning Characteristics

- ASTM E 84
- Flame spread: 15
- Smoke developed: 0

Fire resistance ratings represent the results of tests on assemblies made up of specific materials in a specific configuration. When selecting construction designs to meet certain fire resistance requirements, caution must be used to ensure that each component of the assembly is the one specified in the test. Further, precaution should be taken that assembly procedures are in accordance with those of the tested assembly.

Specifications

The following paragraphs are for insertion into sections of generic specifications or generic/proprietary specifications covering gypsum wallboard products. The National Gypsum product name follows the generic description in parentheses.

Part 2 Products

A. Fire, Abuse and Mold/Mildew-Resistant Gypsum Board: A gypsum core wall panel with additives to enhance the fire resistance, surface indentation resistance, and impact resistance of the core; surfaced with abrasion resistant, moisture/mold/mildew resistant paper on the front, back and long edges and complying with ASTM C 36 and C 1396, Type X. (Hi-Abuse XP Wallboard)

1. Thickness: 5/8"
2. Width: 4'
3. Length: 8' through 12'
4. Edges: Tapered
5. Surface Abrasion Resistance: Not greater than .015" depth when tested at 50 cycles in accordance with ASTM D 4977, Modified.
6. Indentation Resistance: Not greater than .132" depth when tested at an impact load of 72 in.-lbs. in accordance with ASTM D 5420.
7. Impact/Penetration Resistance: Not less than 210 ft.-lbs. required to penetrate when tested in accordance with ASTM E 695 Modified.

8. Mold/Mildew Resistance: Panel score of 10 when tested in accordance with ASTM D 3273.

Part 3 Execution

3.01 Installation

A. General: In accordance with the manufacturer's recommendations, National Gypsum Company *Gypsum Construction Guide*.

Mold and Mildew Resistance*

Hi-Abuse XP Wallboard has been designed to provide extra protection against mold and mildew compared to standard wallboard products. When tested by an independent lab per ASTM D 3273 ("Standard Test Method for Resistance to Growth of Mold on the Surface of Interior Coatings in an Environmental Chamber"), Hi-Abuse XP Wallboard achieved a score of 10, the best possible score for this test.

*The use of Hi-Abuse XP Wallboard in actual installations may not produce the same results as were achieved in controlled, laboratory conditions. No material can be considered "mold proof," nor is it certain that any material will resist mold or mildew indefinitely. When used in conjunction with good design, handling and construction practices, Hi-Abuse XP Wallboard can provide increased mold resistance versus standard wallboard products. As with any building material, avoiding water exposure during handling, storage and installation and after installation is complete is the best way to avoid the formation of mold or mildew.

Technical Information

The primary function of abuse resistant panels is to provide increased resistance to surface damage over standard wallboard. The following technical data illustrates the increased performance of Hi-Abuse XP Wallboard. If resistance to impact by hard objects is desired, Hi-Impact XP Wallboard is recommended.

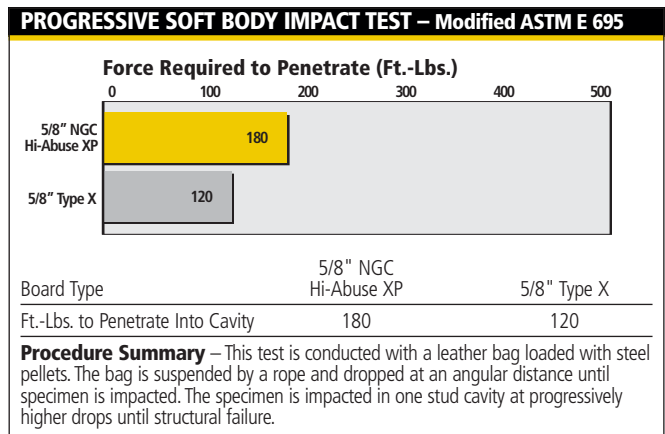
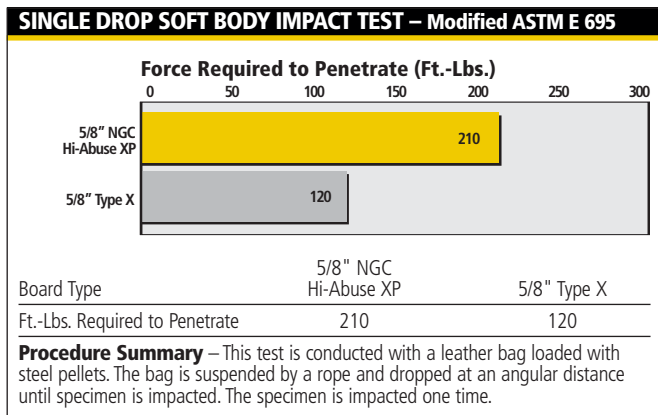
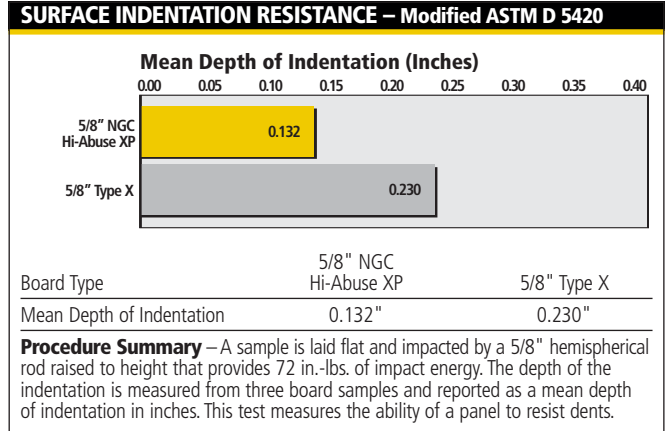
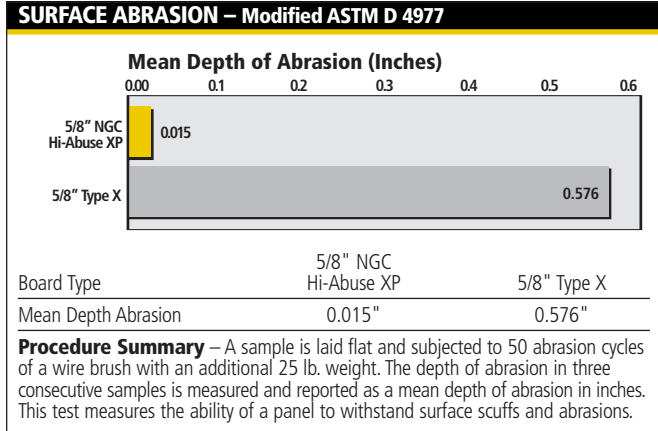

Hi-Abuse[®] BRAND XP[®] Wallboard Fire-Rated Selector Guide

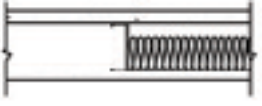
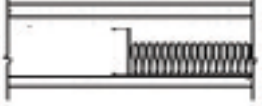
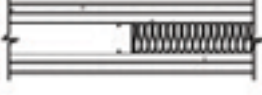
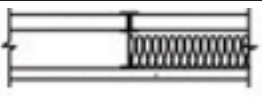
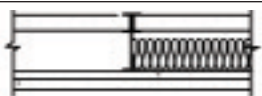
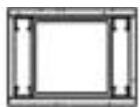
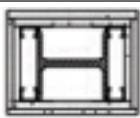
GYPSON WALLBOARD PARTITIONS – STEEL FRAMING CAD File Name GoldU.dwg						
Fire Rating		Ref.	Design No.	Description	STC	Test No.
SINGLE LAYER 3-5/8" STUDS						
1 hr.		UL	U465	5/8" Fire-Shield Hi-Abuse XP Gypsum Wallboard, screw attached vertically with fasteners 8" o.c. at edges and 12" o.c. in the field of the board to 3-5/8", 20 gauge steel studs spaced 16" o.c. with joints staggered on opposite sides of the wall. 2-1/2" glass fiber in cavity.	40	NGC 2501
		UL	V438		44	NGC 2495
UNBALANCED 3-5/8" STUDS						
1 hr.		GA	WP1052	5/8" Fire-Shield Hi-Abuse XP Gypsum Wallboard, screw attached vertically with fasteners 8" o.c. at edges and 12" o.c. in the field of the board to 3-5/8", 20 gauge steel studs spaced 16" o.c. with joints staggered on opposite sides of the wall. 2-1/2" glass fiber in cavity.	47	Based on NGC 2497
DOUBLE LAYER 3-5/8" STUDS						
2 hr.		UL	U411	Base layer 5/8" Fire-Shield Wallboard or 5/8" Fire-Shield Hi-Abuse XP applied vertically to 3-5/8", 20 gauge steel studs spaced 16" o.c. with 1" Type S screws spaced 16" o.c. Face layer 5/8" Fire-Shield Hi-Abuse XP Wallboard staggered one stud cavity applied vertically with 1-5/8" Type S screws spaced 16" o.c. with screws offset 8" from the first layer. 2-1/2" glass fiber in cavity.	52	NGC 2517
		UL	V438			
GYPSON WALLBOARD PARTITIONS – SHAFTWALLS CAD File Name GoldU.dwg						
Fire Rating		Ref.	Design No.	Description	STC	Test No.
1-HOUR SHAFTWALL						
1 hr.		UL	U499	2-1/2", 4" or 6" C-H, C-T or I-Studs 24" o.c. 1" Fire-Shield Shaftliner or 1" Fire-Shield Shaftliner XP, one layer of 5/8" Fire-Shield Hi-Abuse XP Wallboard applied vertically on side opposite shaftliner with 1" Type S steel screws, 12" o.c. Fire tested both sides. 1-1/2" (38.1 mm) mineral wool or glass fiber in cavity.	Est. 36	
					42	NGC 2542
2-HOUR SHAFTWALL						
2 hr.		GA	WP 7076	2-1/2", 4" or 6" I-Studs 24" o.c. 1" Fire-Shield Shaftliner or 1" Fire-Shield Shaftliner XP. Base layer 5/8" Fire-Shield or 5/8" Hi-Abuse XP wallboard applied horizontally on opposite side shaftliner attached with 1" Type S steel screws, 24" o.c. Face layer 5/8" Hi-Abuse XP attached vertically with 1-5/8" Type S screws 12" o.c. Fire tested both sides. 1-1/2" (38.1 mm) mineral wool or glass fiber in cavity.	40	Based on NGC 2615
					47	Based on NGC 2616
GYPSON WALLBOARD COLUMN FIREPROOFING CAD File Name GoldU.dwg						
Fire Rating		Ref.	Design No.	Description		
LIGHT COLUMN						
1 hr.		UL GA	X528 CM 1851	One layer 5/8" Hi-Abuse XP wallboard screw attached with 1" Type S screws 12 o.c. to 1-5/8" 25 gauge minimum steel studs. Stud length to be 1/2" less than assembly height. Joints finished to minimum thickness of 1/16".		
(10WF-49)						
2 hr.		UL GA	X528 CM 2017	Two layers of 5/8" Hi-Abuse XP or 5/8" Fire-Shield wallboard screw attached to 1-5/8" 25 gauge minimum steel studs. First layer attached with 1" Type S screws, 24" o.c. Second layer attached with 1-3/4" Type S screws 12 o.c. Stud length to be 1/2" less than assembly height. Joints finished to minimum thickness of 1/16".		

Hi-Impact[®] BRAND XP[®] Wallboard

Classification Level 3 – Heavy Duty

- Commercial**
- Shopping Centers
 - Airports
 - Mail Rooms
 - Loading Docks
- Institutional**
- Court Houses
 - Police Stations
 - Schools
 - Dormitories
 - Gymnasiums
 - Sports Facilities
 - Health Care Facilities
 - Correctional Facilities

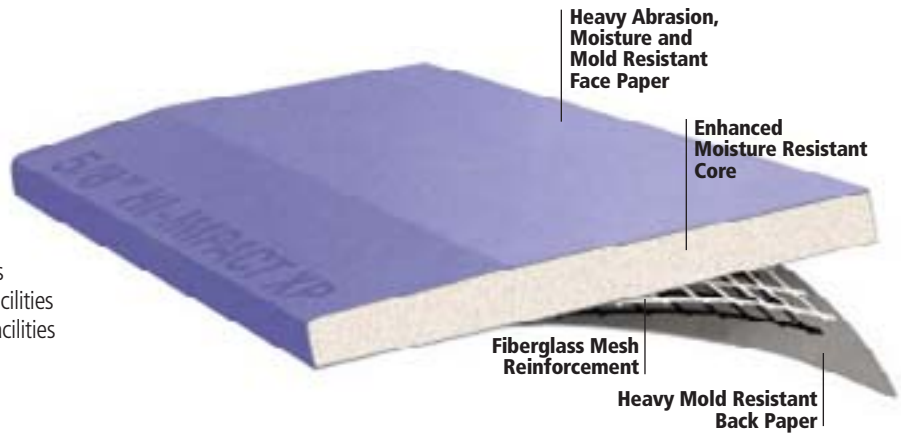

Description

Hi-Impact[®] BRAND XP[®] Wallboard panels consist of a tapered edge, moisture resistant, fire resistant, Type X gypsum core encased in 100% recycled heavy, smooth, moisture, mold/mildew and abrasion resistant purple paper on the face side and strong 100% recycled mold and mildew resistant liner paper on the back side. A fiberglass mesh is embedded into the core, close to the back of the board to provide additional impact/penetration resistance. Hi-Impact XP Wallboard features a specially formulated core to provide fire resistance ratings when used in tested systems in addition to providing extra protection against mold and mildew compared to standard wallboard products.

Applications

This unique wallboard is designed for use in wall assemblies in areas where surface durability, impact/penetration, moisture, mold and mildew resistance are major concerns.

5/8" Fire-Shield Hi-Impact XP panels may be used where Type X gypsum panels are specified in some fire-rated wall assemblies (i.e., UL U300, U400 and V400 series).

Limitations

- Not recommended where it will be exposed to temperatures exceeding 125°F (52°C) for extended periods of time.
- Hi-Impact XP should not be used as a backerboard directly behind tile in tub and shower areas.
- Must be stored off the ground and under cover. Sufficient risers must be used to ensure support for the entire length of the wallboard to prevent sagging.
- Hi-Impact XP should not be used in areas subject to constant and/or excessive moisture and high humidity such as gang showers, saunas, steam rooms and swimming pool enclosures. PermaBase[®] BRAND Cement Board is recommended for these areas.
- Gypsum Wallboard must be kept dry to minimize the potential for mold growth. Adequate care should be taken while transporting, storing, applying and maintaining gypsum wallboard. For additional information, refer to the Gypsum Association publication, "Guidelines for the Prevention of Mold Growth on Gypsum Wallboard" (GA-238-03), which is available at www.gypsum.org under the "Download Free Gypsum Association Publications" section.

FEATURES	BENEFITS
Encased in heavy, smooth, purple, abrasion, moisture, mold and mildew resistant 100% recycled paper	<ul style="list-style-type: none"> ■ Resists the growth of mold per ASTM D 3273 with a score of 10, the best possible score for this test ■ Scuff and scratch resistant ■ Does not require the added strength of a setting type compound for joint reinforcement ■ Allows for same joint treatment reinforcement procedures as standard drywall, thereby reducing cost and the risk of improper installation ■ Accepts a wide range of decorative finishes
High density, fire resistant, moisture resistant Type X core	<ul style="list-style-type: none"> ■ May be used in fire rated wall assemblies requiring a Type X core ■ Indentation resistant ■ Hi-Impact XP can be used as a tile backerboard in dry areas or areas with limited water exposure such as toilet/sink areas and areas above tile in tubs and showers ■ Transitions into drywall without the use of control joints
Core embedded layer of impact resistant mesh	<ul style="list-style-type: none"> ■ Increased resistance to soft body and hard body impacts
Easily scored and snapped	<ul style="list-style-type: none"> ■ Saves time by eliminating the need for special cutting tools and rasping of cut edges ■ Openings and outlet boxes are cut out in same manner as standard wallboard
Lightweight alternative to CMU	<ul style="list-style-type: none"> ■ Faster installation ■ Reduces cost of installation

Applicable Standards

- ASTM C 630/C 1396

Accessories

- Fasteners: drywall screws
- ProForm Joint Tape
- ProForm XP Ready Mix or ProForm Sta-Smooth/Sta-Smooth Lite Setting Compound
- Cornerbead, Trims, Casing beads
- Furring channels
- E-Z Strip control joints or .093 zinc control joints

Installation

- Installation of Hi-Impact XP Fire-Shield Wallboard should be consistent with methods described in Applicable Standards. For best impact performance, use vertical application.
- Listed impact/penetration ratings apply to walls constructed with Hi-Impact XP Wallboard applied with long edges parallel to and centered over minimum 20 gauge framing members spaced a maximum of 16" o.c.
- Hi-Impact XP Wallboard comes standard with GridMarX[®] guide marks printed on the paper surface. These guide marks align with standard building dimensions and help to quickly identify fastener lines for stud and joist framing. Using GridMarX, accurate cuts can be made without having to draw lines. The use of GridMarX also provides quick identification and uniform nail/screw patterns.
- GridMarX guide marks run the machine direction of the board at five points in 4" increments. Marks run along the edge in both tapers and at 16", 24" and 32" in the field of the board. The marks cover easily with no bleed-through using standard paint products.

Applicable Standards and References

- ASTM C 840
- Gypsum Association GA-214
- Gypsum Association GA-216
- National Gypsum Company, *Gypsum Construction Guide*

Finishing/Decoration

- Tapered edges allow joints to be reinforced with ProForm Joint Tape and concealed with ProForm Ready Mix or setting compounds.
- For optimum mold and mildew resistance, National Gypsum recommends ProForm XP Ready Mix or ProForm Sta-Smooth/Sta-Smooth Lite Setting Compounds.
- For best painting results, all surfaces, including joint compound, should be clean, dust-free and not glossy. To improve fastener and joint concealment, a coat of quality drywall primer is recommended to equalize the porosities between surface paper and joint compound. The selection of a paint to give the specified or desired finish characteristics is the responsibility of the architect or contractor.
- Hi-Impact XP Wallboard that is to have a wall covering applied to it should be prepared and primed as described for painting.
- Gypsum Associations GA 214, Recommended Specification of Gypsum Board Finish, should be referred to in order to determine the level of finishing needed to assure a surface properly prepared to accept the desired decoration.

Technical Data

Sizes & Types

- Thickness: 5/8" Type X (15.9mm)
- Width: 4' (1219 mm)
- Lengths: 8' through 12' (2438 mm-3658 mm)
- Edges: Tapered

Surface Burning Characteristics

- ASTM E 84
- Flame spread: 15
- Smoke developed: 0

Fire resistance ratings represent the results of tests on assemblies made up of specific materials in a specific configuration. When selecting construction designs to meet certain fire resistance requirements, caution must be used to ensure that each component of the assembly is the one specified in the test. Further, precaution should be taken that assembly procedures are in accordance with those of the tested assembly.

Specifications

The following paragraphs are for insertion into sections of generic specifications or generic/proprietary specifications covering gypsum wallboard products. The National Gypsum product name follows the generic description in parentheses.

Part 2 Products

A. Fire, Impact/Penetration and Mold/Mildew/Moisture Resistant Gypsum Board: A gypsum core wall panel with additives to enhance the fire resistance, water resistance, surface indentation resistance, and impact resistance of the core; surfaced with abrasion mold/mildew/moisture resistant paper on the front, back and long edges with a fiberglass mesh embedded in the board to enhance impact/penetration resistance and complying with ASTM C 630 and C 1396, Type X. (Hi-Impact XP Wallboard)

1. Thickness: 5/8"
2. Width: 4'
3. Length: 8' through 12'
4. Edges: Tapered
5. Surface Abrasion Resistance: Not greater than .015" depth when tested at 50 cycles in accordance with ASTM D 4977, Modified.

6. Indentation Resistance: Not greater than .114" depth when tested at a impact load of 72 in.-lbs. in accordance with ASTM D 5420.
7. Impact/Penetration Resistance: not less than 540 ft.-lbs. When tested in accordance with ASTM E 695, Modified.
8. Mold/Mildew Resistance: Panel score of 10 when tested in accordance with ASTM D 3273.

Part 3 Execution

3.01 Installation

A. General: In accordance with the manufacturer's recommendations, National Gypsum Company, *Gypsum Construction Guide*.

Mold and Mildew Resistance

Hi-Impact XP Wallboard has been designed to provide extra protection against mold and mildew compared to standard wallboard products. When tested by an independent lab per ASTM D 3273 ("Standard Test Method for Resistance to Growth of Mold on the Surface of Interior Coatings in an Environmental Chamber"), Hi-Impact XP Wallboard achieved a score of 10, the best possible score for this test.

*The use of Hi-Impact XP Wallboard in actual installations may not produce the same results as were achieved in controlled, laboratory conditions. No material can be considered "mold proof," nor is it certain that any material will resist mold or mildew indefinitely. When used in conjunction with good design, handling and construction practices, Hi-Impact XP Wallboard can provide increased mold resistance versus standard wallboard products. As with any building material, avoiding water exposure during handling, storage and installation and after installation is complete is the best way to avoid the formation of mold or mildew.

Technical Information

The primary function of impact resistant panels is to provide increased resistance to panel breakage and penetration into the wall cavity while offering increased resistance to surface damage. The following technical data illustrates the increased performance of Hi-Impact XP Wallboard over standard wallboard.

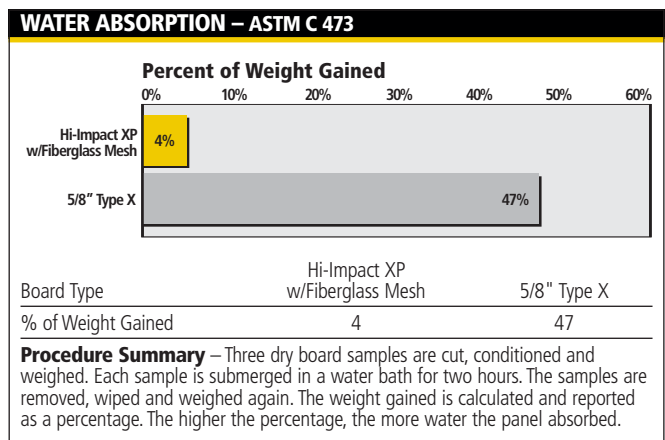
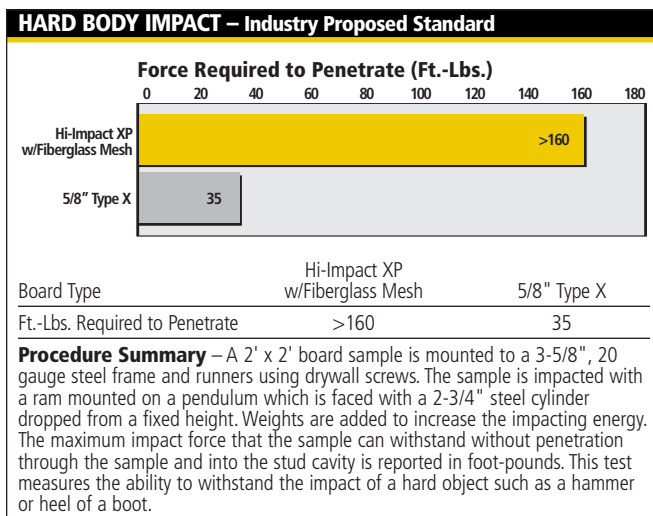
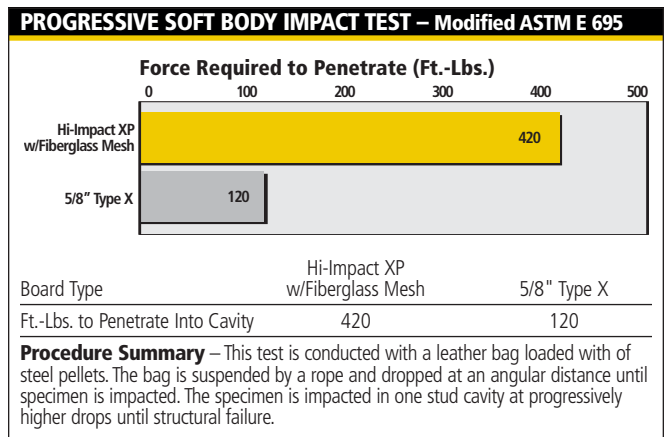
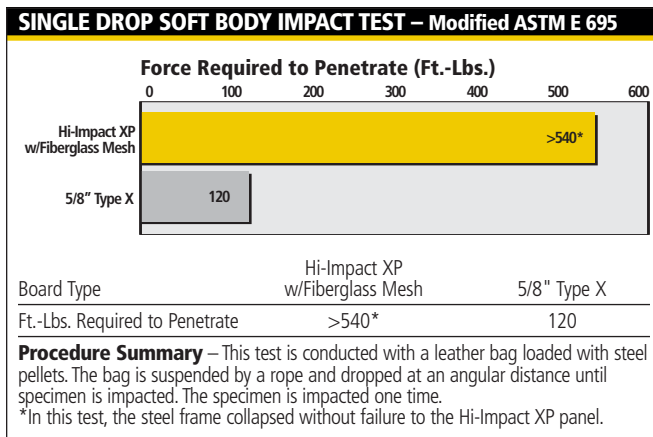
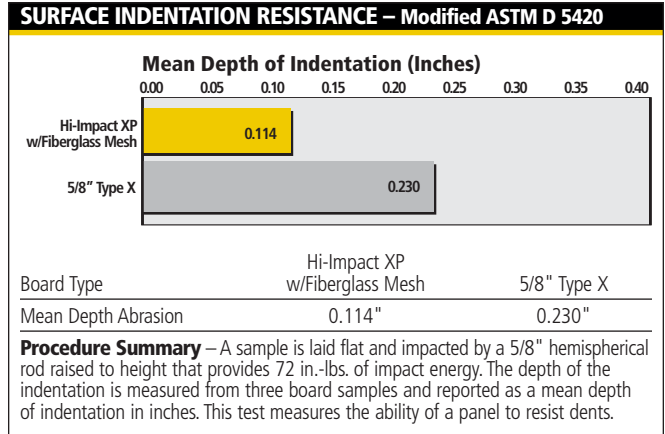
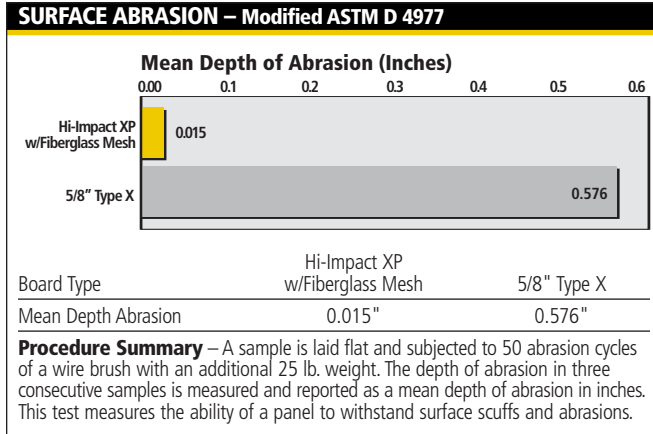

Hi-Impact[®] BRAND XP[®] over Hi-Impact[®] BRAND XP[®]

Classification Level 4 – Maximum Duty

- Commercial**
- Shopping Centers
 - Airports
 - Mail Rooms
 - Loading Docks
- Institutional**
- Court Houses
 - Police Stations
 - Schools
 - Dormitories
 - Gymnasiums
 - Sports Facilities
 - Health Care Facilities
 - Correctional Facilities

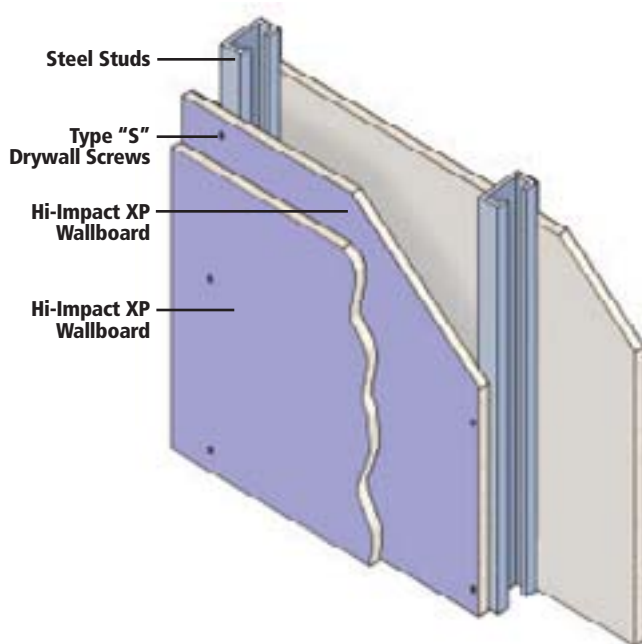

Description

Achieving heavy-duty status is as easy as adding a second layer of Hi-Impact XP Wallboard. Additional layers can be added to one or both sides of a wall assembly. Two layers of Hi-Impact XP provide up to 260 ft.-lbs. of hard body impact resistance while maintaining the same mold, mildew and moisture resistance of the wall. Double layering one side of a wall assembly maintains a 1-hour fire rating. Double layering both sides of a wall assembly increases the system fire rating to 2 hours.

Applications

This unique wallboard is designed for use in wall assemblies in areas where surface durability, impact/penetration, moisture, mold and mildew resistance are major concerns.

5/8" Fire-Shield Hi-Impact XP panels may be used where Type X gypsum panels are specified in some fire rated wall assemblies (i.e., UL U300, U400 and V400 series).

Technical Information

SURFACE ABRASION – Modified ASTM D 4977

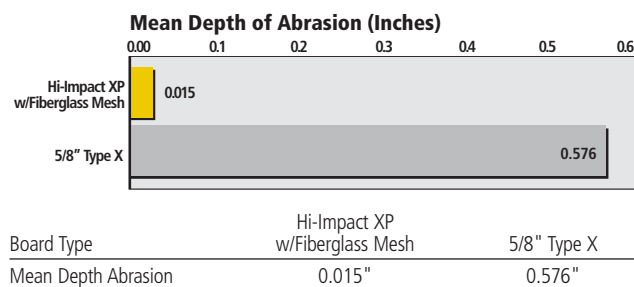

Procedure Summary – A sample is laid flat and subjected to 50 abrasion cycles of a wire brush with an additional 25 lb. weight. The depth of abrasion in three consecutive samples is measured and reported as a mean depth of abrasion in inches. This test measures the ability of a panel to withstand surface scuffs and abrasions.

SURFACE INDENTATION RESISTANCE – Modified ASTM D 5420

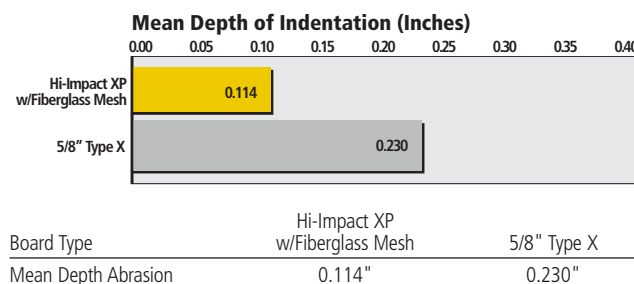

Procedure Summary – A sample is laid flat and impacted by a 5/8" hemispherical rod raised to height that provides 72 in./lbs. of impact energy. The depth of the indentation is measured from three board samples and reported as a mean depth of indentation in inches. This test measures the ability of a panel to resist dents.

HARD BODY IMPACT – Industry Proposed Standard

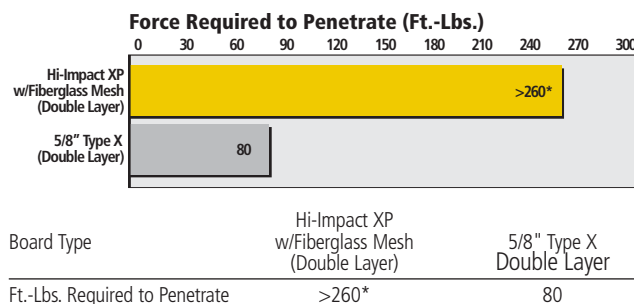



Procedure Summary – A 2' x 2' board sample is mounted to a 3-5/8", 20 gauge steel frame and runners using drywall screws. The sample is impacted with a ram mounted on a pendulum which is faced with a 2-3/4" steel cylinder dropped from a fixed height. Weights are added to increase the impacting energy. The maximum impact force that the sample can withstand without penetration through the sample and into the stud cavity is reported in foot-pounds. This test measures the ability to withstand the impact of a hard object such as a hammer or heel of a boot.

* Performance of the system exceeded the capability of the testing apparatus.

Tests witnessed by H. P. White Laboratory, Inc. except Hard Body Impact.

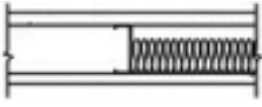
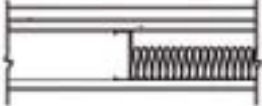
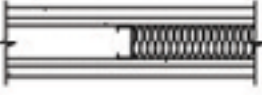
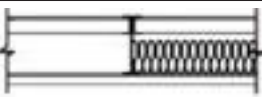
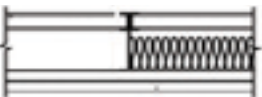
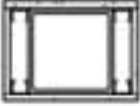
Hi-Impact[®] BRAND XP[®] Wallboard Fire-Rated Selector Guide

GYPSUM WALLBOARD PARTITIONS – STEEL FRAMING CAD File Name GoldV.dwg						
Fire Rating		Ref.	Design No.	Description	STC	Test No.
SINGLE LAYER 3-5/8" STUDS						
1 hr.		UL UL	U465 V438	5/8" Fire-Shield Hi-Impact XP Gypsum Wallboard, screw attached vertically with fasteners 8" o.c. at edges and 12" o.c. in the field of the board to 3-5/8", 20 gauge steel studs spaced 16" o.c. with joints staggered on opposite sides of the wall. 2-1/2" glass fiber in cavity.	40 44	NGC 2501 NGC 2495
UNBALANCED 3-5/8" STUDS						
1-1/2 hr.		GA	WP1052	5/8" Fire-Shield Hi-Impact XP Gypsum Wallboard, screw attached vertically with fasteners 8" o.c. at edges and 12" o.c. in the field of the board to 3-5/8", 20 gauge steel studs spaced 16" o.c. with joints staggered on opposite sides of the wall. 2-1/2" glass fiber in cavity.	47	Based on NGC 2497
DOUBLE LAYER 3-5/8" STUDS						
2 hr.		UL UL	U411 V438	Base layer 5/8" Fire-Shield Wallboard or 5/8" Fire-Shield Hi-Impact XP applied vertically to 3-5/8", 20 gauge steel studs spaced 16" o.c. with 1" Type S screws spaced 16" o.c. Face layer 5/8" Fire-Shield Hi-Impact XP Wallboard staggered one stud cavity applied vertically with 1-5/8" Type S screws spaced 16" o.c. with screws offset 8" from the first layer. 2-1/2" glass fiber in cavity.	52	NGC 2517
GYPSUM WALLBOARD PARTITIONS – SHAFTWALLS CAD File Name GoldV.dwg						
Fire Rating		Ref.	Design No.	Description	STC	Test No.
1-HOUR SHAFTWALL						
1 hr.		UL	U499	2-1/2", 4" or 6" C-H, C-T or I-Studs 24" o.c. 1" Fire-Shield Shaftliner or 1" Fire-Shield Shaftliner XP, one layer of 5/8" Fire-Shield Hi-Impact XP Wallboard applied vertically on side opposite shaftliner with 1" Type S steel screws, 12" o.c. Fire tested both sides. 1-1/2" (38.1 mm) mineral wool or glass fiber in cavity.	Est. 36 42	 NGC 2542
2-HOUR SHAFTWALL						
2 hr.		GA	WP 7076	2-1/2", 4" or 6" I-Studs 24" o.c. 1" Fire-Shield Shaftliner or 1" Fire-Shield Shaftliner XP. Base layer 5/8" Fire-Shield or 5/8" Hi-Impact XP wallboard applied horizontally on opposite side shaftliner attached with 1" Type S steel screws, 24" o.c. Face layer 5/8" Hi-Impact XP attached vertically with 1-5/8" Type S screws 12" o.c. Fire tested both sides. 1-1/2" mineral wool or glass fiber in cavity.	40 47	Based on NGC 2615 Based on NGC 2616
GYPSUM WALLBOARD COLUMN FIREPROOFING CAD File Name GoldV.dwg						
Fire Rating		Ref.	Design No.	Description		
LIGHT COLUMN						
1 hr.		UL GA	X528 CM 1851	One layer 5/8" Hi-Impact XP wallboard screw attached with 1" Type S screws 12 o.c. to 1-5/8" 25 gauge minimum steel studs. Stud length to be 1/2" less than assembly height. Joints finished to minimum thickness of 1/16".		
(10WF-49)						
2 hr.		UL GA	X528 CM 2017	Two layers of 5/8" Hi-Impact XP or 5/8" Fire-Shield wallboard screw attached to 1-5/8" 25 gauge minimum steel studs. First layer attached with 1" Type S screws, 24" o.c. Second layer attached with 1-3/4" Type S screws 12 o.c. Stud length to be 1/2" less than assembly height. Joints finished to minimum thickness of 1/16".		

Mold Resistance Products and Recommendations by National Gypsum

National Gypsum offers products that provide extra protection against mold and mildew including the XP® family of gypsum wallboard products, ProForm® BRAND XP® Ready Mix and PermaBase® BRAND

Cement Board. The XP family of gypsum wallboard products includes Gold Bond® BRAND XP® Wallboard, Gold Bond® BRAND Shaftliner XP®, Hi-Abuse BRAND XP® and Hi-Impact BRAND XP®.

No material can be considered “mold-proof,” nor is it certain that any material will resist mold or mildew indefinitely. When used in conjunction with good design, handling and construction practices,

XP products and PermaBase Cement Board can provide increased mold resistance versus standard wallboard products.

Handling and Construction Practices

Transportation and Receiving

- Gypsum board must be protected during transit with a weather-tight cover in good condition.
- Plastic shipping bags are intended to provide protection during transit only and must be promptly removed upon arrival of the load. Failure to remove the shipping bag can increase the likelihood of developing conditions favorable to the growth of mold.

Storage and Handling

- Gypsum board must be stored in an area that protects it from adverse weather conditions, condensation, and other forms of moisture.

- Job site conditions that can expose gypsum board to water or moisture must be avoided.
- Gypsum board must be delivered to the job site as near to the time it will be used as possible.

Application

- Provisions must be made to keep gypsum board dry throughout application.
- Gypsum board that has visible mold growth must not be used.
- Gypsum board on walls must be applied with a minimum 1/4” (6 mm) gap between the gypsum board and the floor.
- Gypsum board must not be applied over other building materials where conditions exist that are favorable to mold growth.

Maintenance Following Application

- Essential elements of a sound weather-tight building envelope must be properly maintained, such as the roof, sealants, windows, etc.
- Immediate and appropriate remediation measures must be taken as soon as water leaks or condensation sources are identified.
- Routine cleaning and maintenance operations must be performed to prevent saturation of the gypsum board.

Good Design Practices

- Design the building envelope and wall system to prevent moisture and water intrusion with special attention to windows, doors, roof lines, floor lines and soffit systems.
- Proper design of the ventilation systems to provide for managing airflows within the building including a system to allow for maintaining indoor relative humidity below 60%.
- Correct design and implementation of vapor barriers.
- Ensure that all related products and subsystems are compatible and work together as a complete system.

Additional Sources of Information

- *Guidelines for Prevention of Mold Growth on Gypsum Board* (GA-238-03)
- *Application and Finishing of Gypsum Board* (GA-216-00), published by the Gypsum Association (www.gypsum.org)
- *The Humidity Control Design Guide for Commercial and Institutional Buildings*, published by the American Society of Heating, Refrigerating and Air-Conditioning Engineers (ASHRAE) (www.ashrae.org)
- *Mold: Cause, Effect and Response*, published by the Foundation of the Wall and Ceiling Industry, (www.awci.org)

CUSTOMER SERVICE SALES AREAS

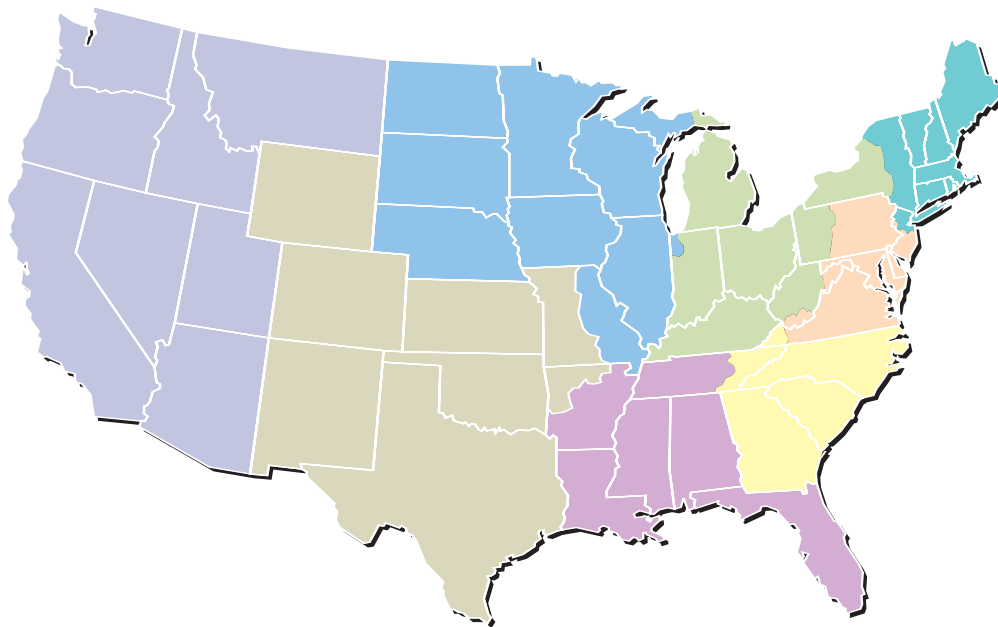

Atlantic Area

Phone: (800) 237-9167
Fax: (877) 252-0430

Central Area

Phone: (800) 252-1065
Fax: (866) 232-0440

Gulf Area

Phone: (800) 343-4893
Fax: (866) 482-8940

Midwest Area

Phone: (800) 323-1447
Fax: (866) 692-8590

Northeast Area

Phone: (800) 253-3161
Fax: (800) 443-1329

Southeast Area

Phone: (800) 548-9394
Fax: (800) 442-2793

Southwest Area

Phone: (800) 548-9396
Fax: (866) 792-7520

Western Area

Phone: (800) 824-4227
Fax: (800) 438-6266

National Accounts

Phone: (800) 440-1230
Fax: (866) 622-3590

Manufactured Housing

Phone: (800) 455-3185
Fax: (800) 639-1714

LIMITED WARRANTY AND REMEDIES

Products manufactured and sold by National Gypsum are warranted by National Gypsum to its customers to be free from defects in materials and workmanship at the time of shipment. **THIS EXPRESS WARRANTY IS THE ONLY WARRANTY APPLICABLE TO SUCH PRODUCTS, AND IS IN LIEU OF AND EXCLUDES ALL OTHER EXPRESS ORAL OR WRITTEN WARRANTIES AND ALL IMPLIED WARRANTIES, INCLUDING BUT NOT LIMITED TO THE IMPLIED WARRANTIES OF MERCHANTABILITY AND FITNESS FOR A PARTICULAR PURPOSE.**

National Gypsum will not be liable for any incidental, indirect or consequential losses, damages or expenses. The customer's exclusive remedy for any type of claim or action for defective products will be limited to the replacement of the products (in the form originally shipped) or, at National Gypsum's option, to a payment or credit not greater than the original purchase price of the products.

National Gypsum will not be liable for products claimed to be defective where the defect resulted from causes not within National Gypsum's control, or which arose or occurred after shipment, including but not limited to accidents, misuse, mishandling, improper installation, contamination or adulteration by other materials or goods, or abnormal conditions of temperature, moisture, dirt or corrosive matter.

Any claim that products sold by National Gypsum were defective or otherwise did not conform to the contract of sale is waived unless the customer submits it in writing to National Gypsum within thirty (30) days from the date the customer discovered or should have discovered the defect or nonconformance. No legal action or proceeding complaining of goods sold by National Gypsum may be brought by the customer more than one year after the date the customer discovered or should have discovered the defect or problem of which it complains.

Corporate Headquarters

National Gypsum Company
2001 Rexford Road
Charlotte, NC 28211
Phone: (704) 365-7300
Web: nationalgypsum.com

Technical Information

Phone: (800) NATIONAL
(800) 628-4662
Fax: (800) FAX-NGC1
(800) 329-6421

National 
Gypsum®

Excellence Across The Board®